

# DATA SHEET

## **TDA5332T**

Double mixer/oscillator for TV and  
VCR tuners

Preliminary specification  
File under Integrated Circuits, IC02

March 1989

## Double mixer/oscillator for TV and VCR tuners

## TDA5332T

### GENERAL DESCRIPTION

The TDA5332T is an integrated circuit that performs the mixer/oscillator functions in TV and VCR tuners. This device gives the designer the capability to design an economical and physically small tuner which will be capable of meeting the most stringent requirements e.g. FTZ or FCC. The tuner development time can be drastically reduced by using this device.

### Features

- Balanced mixer with a common emitter input for band A
- Amplitude-controlled oscillator for band A
- Balanced mixer with common base input for band B
- Balanced oscillator for band B
- SAW filter preamplifier with an output impedance of 75  $\Omega$  in application
- Bandgap voltage stabilizer for oscillator stability
- Electronic bandswitch

### QUICK REFERENCE DATA

PARAMETER	CONDITIONS	SYMBOL	MIN.	TYP.	MAX.	UNIT
Supply voltage		$V_P$	–	12	–	V
Band A frequency range	depending on application	$f_A$	45	–	470	MHz
Band B frequency range	depending on application	$f_B$	160	–	860	MHz
Band A noise factor	50 MHz	$NF_A$	–	7.5	–	dB
Band B noise factor	860 MHz	$NF_B$	–	9	–	dB
Band A input voltage	1% cross-modulation	$V_{18-20}$	–	100	–	$\text{dB}\mu\text{V}$
Band B input power	1% cross-modulation note 5	$P_I$	–	–21	–	dBm
Band A voltage gain		$G_{VA}$	–	25	–	dB
Band B voltage gain		$G_{VB}$	–	36	–	dB

### PACKAGE OUTLINE

20-lead mini-pack, plastic (SO20L; SOT163A); SOT163-1; 1996 November 29.

# Double mixer/oscillator for TV and VCR tuners

## TDA5332T

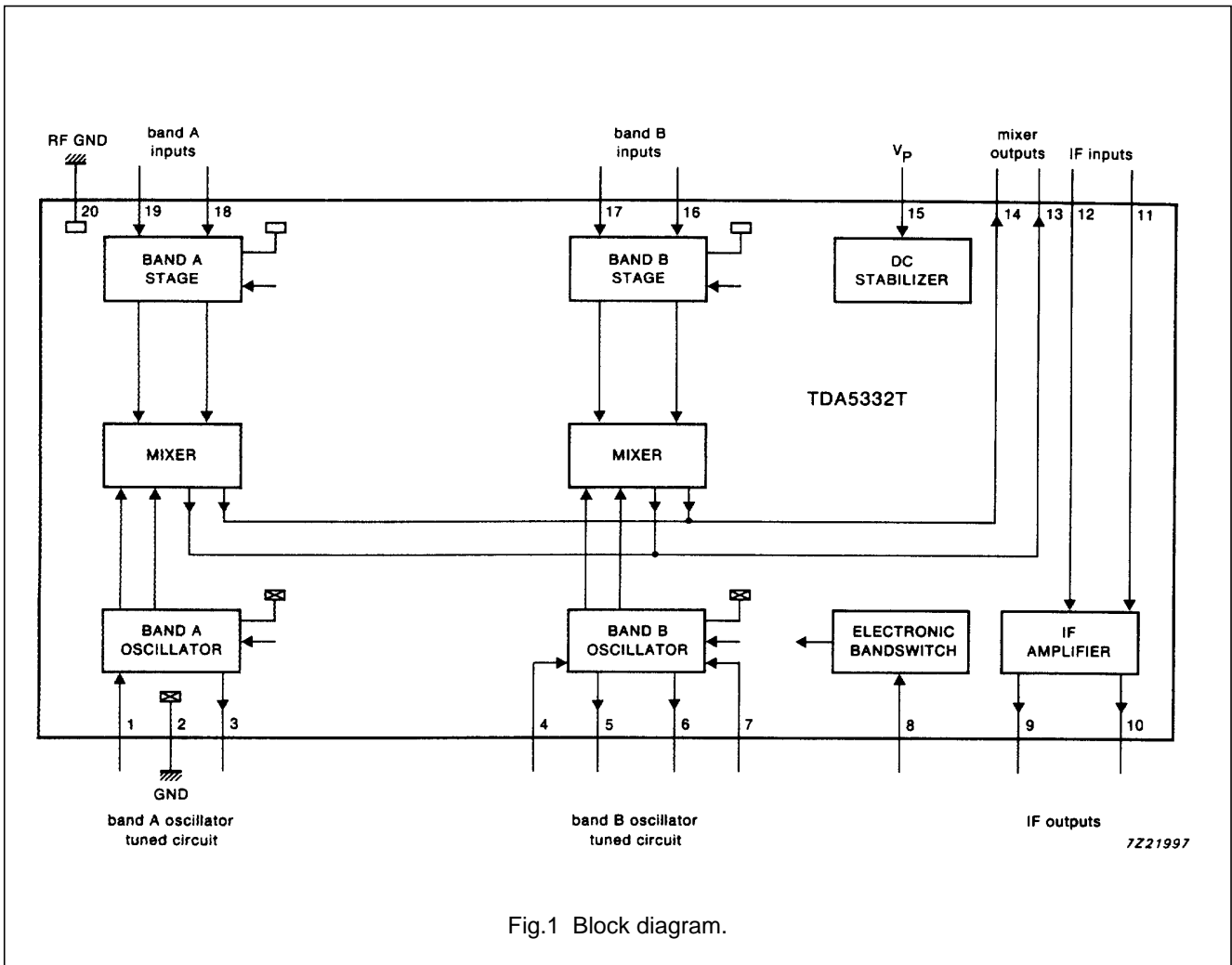

Fig.1 Block diagram.

# Double mixer/oscillator for TV and VCR tuners

TDA5332T

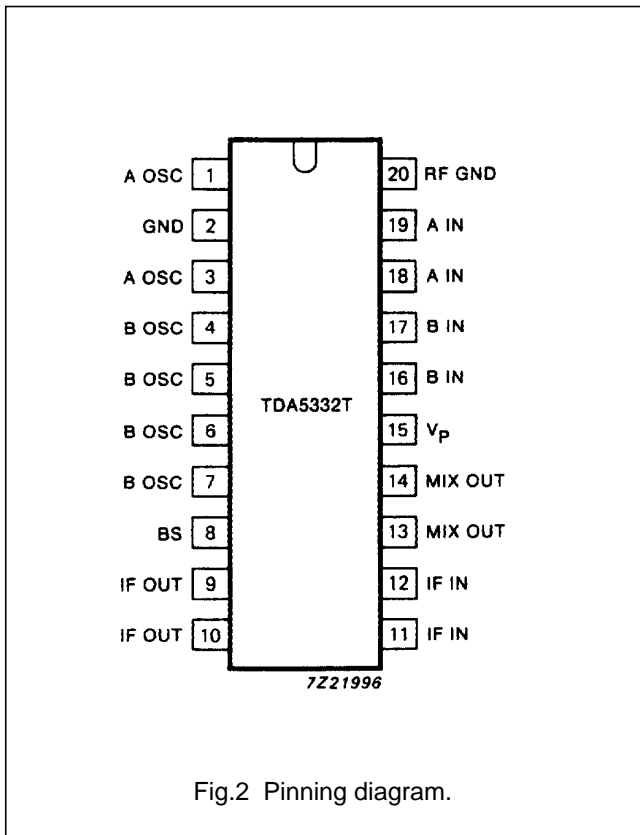

Fig.2 Pinning diagram.

### PINNING

- 1 A OSC band A oscillator input
- 2 GND ground (0 V)
- 3 A OSC band A oscillator output
- 4 B OSC band B oscillator input
- 5 B OSC band B oscillator output
- 6 B OSC band B oscillator output
- 7 B OSC band B oscillator input
- 8 BS electronic bandswitch
- 9 IF OUT IF amplifier output
- 10 IF OUT IF amplifier output
- 11 IF IN IF amplifier input
- 12 IF IN IF amplifier input
- 13 MIX OUT mixer output
- 14 MIX OUT mixer output
- 15 V<sub>p</sub> positive supply voltage
- 16 B IN band B input
- 17 B IN band B input
- 18 A IN band A input
- 19 A IN band A input
- 20 RF GND ground for RF inputs

### RATINGS

Limiting values in accordance with the Absolute Maximum System (IEC 134)

PARAMETER	CONDITIONS	SYMBOL	MIN.	MAX.	UNIT
Supply voltage		V <sub>p</sub>	-0.3	14	V
Switching voltage		V <sub>8</sub>	0	14	V
Output current of each pin to ground		I <sub>o</sub>	-	-10	mA
Maximum short-circuit time (all pins)		t <sub>sc</sub>	-	10	s
Storage temperature range		T <sub>stg</sub>	-55	+ 150	°C
Operating ambient temperature range		T <sub>amb</sub>	-25	+ 80	°C
Junction temperature		T <sub>j</sub>	-	+ 150	°C

### THERMAL RESISTANCE

From junction to ambient in free air R<sub>th j-a</sub> typ. 100 K/W

### HANDLING

Pins 8, 9 and 10 withstand the ESD test in accordance with MIL-STD-883C category B (2000 V).

# Double mixer/oscillator for TV and VCR tuners

TDA5332T

**CHARACTERISTICS**

$V_P = 12\text{ V}$ ;  $T_{amb} = 25\text{ }^\circ\text{C}$ ; all voltages are referenced to ground (pins 2 and 20); measured in Fig.3; unless otherwise specified.

PARAMETER	CONDITIONS	SYMBOL	MIN.	TYP.	MAX.	UNIT
Supply voltage		$V_{15}$	10	–	13.2	V
Supply current		$I_{15}$	–	42	55	mA
Switching voltage;						
band A		$V_{SA}$	0	–	1.1	V
band B		$V_{SB}$	3	–	5	V
Switching current						
band A		$I_{SA}$	–	–	10	$\mu\text{A}$
band B		$I_{SB}$	–	–	50	$\mu\text{A}$
<b>IF Amplifier</b>	differentially measured at 36 MHz					
				mod.	phase	
Input reflection coefficient	note 4	$S_{11}$	–	–0.5	–2	–
Reverse transmission coefficient		$S_{12}$	–	–41	–7	–
Forward transmission coefficient		$S_{21}$	–	12	160	–
Output reflection coefficient		$S_{22}$	–	–9	10	–
Input admittance in application		$Y_I$	–	–	1.4	mS
					0.9	pF
Output admittance in application		$Z_O$	–	–	55	$\Omega$
					230	nH
<b>Band A mixer (including IF amplifier)</b>	measured using circuit shown in Fig.3					
Frequency range		$f_A$	45	–	470	MHz
Noise factor	50 MHz	NF	–	7.5	9	dB
	225 MHz	NF	–	9	11	dB
	300 MHz	NF	–	10	12	dB
	470 MHz	NF	–	11	13	dB
Optimum source conductance	50 MHz	$G_{18-20}$	–	0.5	–	mS
	225 MHz	$G_{18-20}$	–	1.1	–	mS
	300 MHz	$G_{18-20}$	–	1.2	–	mS
	470 MHz	$G_{18-20}$	–	1.9	–	mS

# Double mixer/oscillator for TV and VCR tuners

TDA5332T

PARAMETER	CONDITIONS	SYMBOL	MIN.	TYP.	MAX.	UNIT
Input capacitance	50 – 470 MHz	$C_{18-20}$	–	2.5	–	pF
Input voltage	1% cross-modulation; in channel;	$V_{18-20}$	97	100	–	dB $\mu$ V
Input voltage	10 kHz pulling; in channel; $f < 300$ MHz	$V_{18-20}$	100	108	–	dB $\mu$ V
Voltage gain	20 log ( $V_{9-10}/V_{18}$ )	$G_V$	22.5	25.0	27.5	dB
<b>Band A mixer</b>						
Conversion transadmittance mixer	$I_{13}/V_{18} = -I_{14}/V_{18}$ pins 13 and 14	$C_t$	–	3.5	–	mS
Mixer output admittance			–	0.1	–	mS
Mixer output capacitance		$C_{13-14}$	–	2	–	pF
<b>Band A oscillator</b>						
Frequency range		$f_A$	80	–	520	MHz
Frequency shift	$\Delta V_P = 10\%$ note 6; $f = 330$ MHz	$\Delta f$	–	–	200	kHz
Frequency drift	$\Delta T = 25$ °C note 7; $f = 330$ MHz	$\Delta f$	–	–	400	kHz
Frequency drift	5 s to 15 min after switching on; $f = 330$ MHz	$\Delta f$	–	–	200	kHz
<b>Band B mixer (including IF)</b>						
Frequency range	measured using circuit shown in Fig.3; measurements using hybrid; note 1	$f_B$	160	–	860	MHz
Noise factor not corrected for image	pins 16 and 17					
	160 MHz	$NF_B$	–	9	11	dB
	860 MHz	$NF_B$	–	9	11	dB
Available input power	note 5; 1% cross-modulation; in channel; pins 16 and 17;					
	160 MHz	$P_{IB}$	–25	–21	–	dBm
	860 MHz	$P_{IB}$	–25	–21	–	dBm
10 kHz pulling	note 5; pins 16 and 17; in channel					
	860 MHz		–	–20	–	dBm

## Double mixer/oscillator for TV and VCR tuners

TDA5332T

PARAMETER	CONDITIONS	SYMBOL	MIN.	TYP.	MAX.	UNIT
N + 5 – 1 MHz pulling	notes 2 and 5; 820 MHz		-42	-35	-	dBm
Voltage gain	note 3; 160 MHz	$G_{VB}$	33	36	39	dB
	860 MHz	$G_{VB}$	33	36	39	dB
<b>Band B oscillator</b>						
Frequency range		$f_B$	200	-	900	MHz
Frequency shift	note 6; $\Delta V_P = 10\%$	$\Delta f$	-	-	400	kHz
Frequency drift	note 7; $\Delta T = 25\text{ }^\circ\text{C}$	$\Delta f$	-	-	800	kHz
Frequency drift	5 s to 15 min after switching on	$\Delta f$	-	-	400	kHz

### Notes to the characteristics

- The values have been corrected for hybrid and cable losses. The symmetrical output impedance of the circuit is 100  $\Omega$ .
- The input level of a N + 5 – 1 MHz signal (just visible).
- The gain is defined as the transducer gain (measured in Fig.3) plus the voltage transformation ratio of L6 to L7 (6:1, 16 dB).
- All S parameters are referred to a 50  $\Omega$  system.
- The input power is defined as the power delivered by the generator on a 50  $\Omega$  load.
- The frequency shift is defined for a variation of power supply from;
  - $V_P = 12\text{ V}$  to  $V_P = 10.8\text{ V}$
  - $V_P = 12\text{ V}$  to  $V_P = 13.2\text{ V}$ .
 In both cases the frequency shift is below the specified value.
- The frequency drift is defined for a variation of ambient temperature from;
  - $T_{amb} = 25\text{ }^\circ\text{C}$  to  $T_{amb} = 0\text{ }^\circ\text{C}$
  - $T_{amb} = 25\text{ }^\circ\text{C}$  to  $T_{amb} = 50\text{ }^\circ\text{C}$
 In both cases the frequency shift is below the specified value.

# Double mixer/oscillator for TV and VCR tuners

## TDA5332T

### APPLICATION INFORMATION

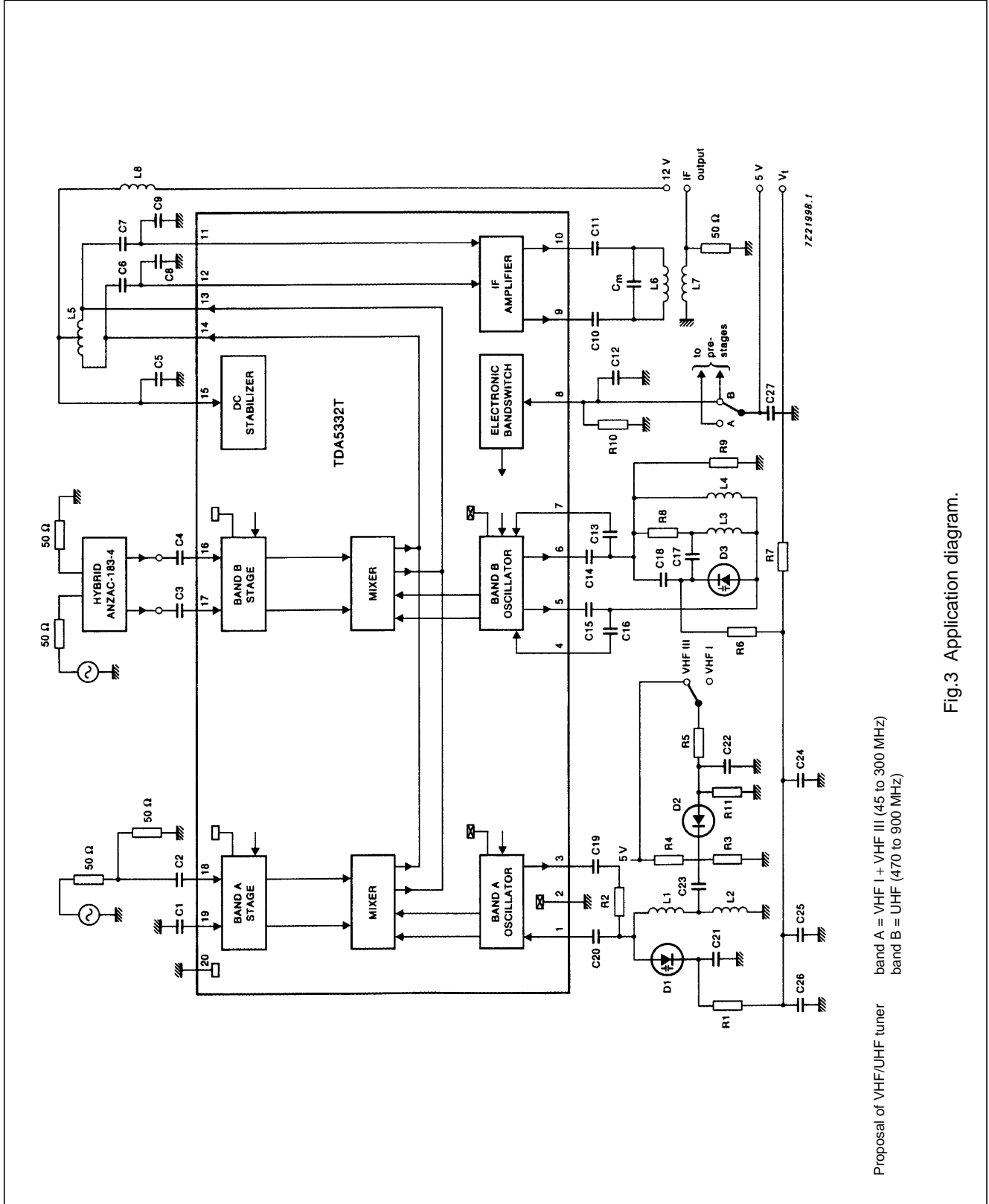

Fig.3 Application diagram.



## Double mixer/oscillator for TV and VCR tuners

TDA5332T

### Component values of the application diagram

#### resistors

R1 = 47 k $\Omega$	R2 = 18 $\Omega$	R3 = 1.2 k $\Omega$	R4 = 4.7 k $\Omega$
R5 = 100 $\Omega$	R6 = 22 k $\Omega$	R7 = 1 k $\Omega$	R8 = 2.2 k $\Omega$
R9 = 22 k $\Omega$	R10 = 15 k $\Omega$	R11 = 47 k $\Omega$	

#### capacitors

C1 = 1 nF	C2 = 1 nF	C3 = 1 nF	C4 = 1 nF
C5 = 1 nF	C6 = 1 nF	C7 = 1 nF	C8 = 15 pF (N750)
C9 = 15 pF (N750)	C10 = 1 nF	C11 = 1 nF	C12 = 1 nF
C13 = 0.68 pF (SMD)	C14 = 1 pF (SMD)	C15 = 1 pF (SMD)	
C16 = 0.68 pF (SMD)	C17 = 100 pF (SMD)	C18 = 5.6 pF (SMD)	C19 = 1 pF (NPO)
C20 = 1 pF (NPO)	C21 = 82 pF (N750)	C22 = 1 nF	C23 = 1 nF
C24 = 1 nF	C25 = 1 nF	C26 = 1 $\mu$ F (40V)	C27 = 1 nF
Cm = 18 pF (N750)			

#### diodes and IC

D1 = BB911	D2 = BA482	D3 = BB405B	IC = TDA5332T
------------	------------	-------------	---------------

#### coils

L1 = 2.5 t ( $\phi$ 3)	L2 = 8.5 t ( $\phi$ 3)	L3 = 1.5 t ( $\phi$ 3)
L4 = 1.5 t ( $\phi$ 3)	L5 = 2 $\times$ 5 t (note 1)	L8 = 5 $\mu$ H (choke coil)

#### transformer

L6 = 12t (note 1)	L7 = 2 t
-------------------	----------

wire size for L1 to L4 = 0.4 and for L5 to L7 = 0.1 mm.

### Note

1. Coil type: TOKO 7 kN; material: 113 kN, screw core (03-0093), pot core (04-0026).

# Double mixer/oscillator for TV and VCR tuners

TDA5332T

## PACKAGE OUTLINE

SO20: plastic small outline package; 20 leads; body width 7.5 mm

SOT163-1

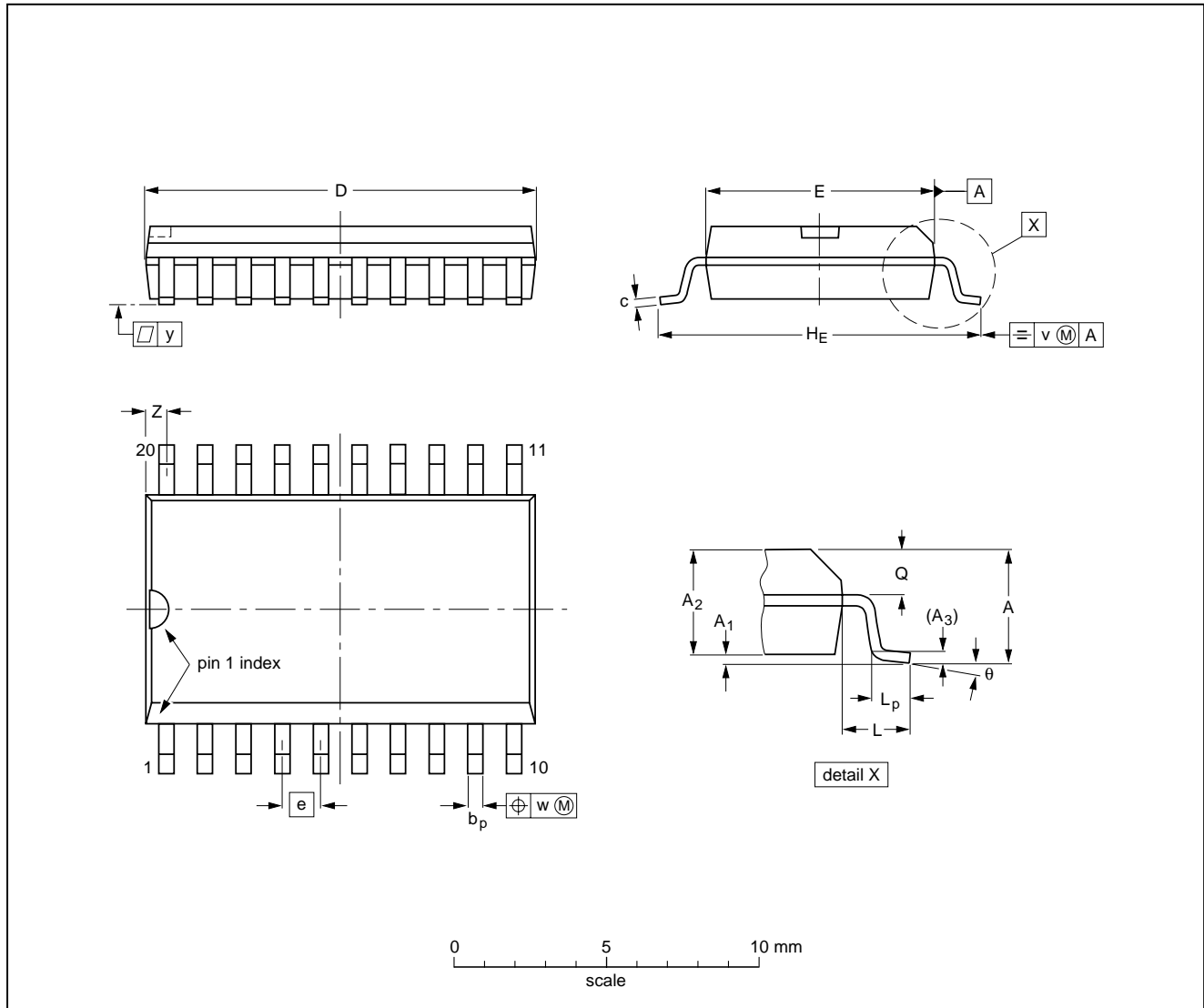

**DIMENSIONS (inch dimensions are derived from the original mm dimensions)**

UNIT	A max.	A <sub>1</sub>	A <sub>2</sub>	A <sub>3</sub>	b <sub>p</sub>	c	D <sup>(1)</sup>	E <sup>(1)</sup>	e	H <sub>E</sub>	L	L <sub>p</sub>	Q	v	w	y	z <sup>(1)</sup>	θ
mm	2.65	0.30 0.10	2.45 2.25	0.25	0.49 0.36	0.32 0.23	13.0 12.6	7.6 7.4	1.27	10.65 10.00	1.4	1.1 0.4	1.1 1.0	0.25	0.25	0.1	0.9 0.4	8° 0°
inches	0.10	0.012 0.004	0.096 0.089	0.01	0.019 0.014	0.013 0.009	0.51 0.49	0.30 0.29	0.050	0.419 0.394	0.055	0.043 0.016	0.043 0.039	0.01	0.01	0.004	0.035 0.016	

**Note**

1. Plastic or metal protrusions of 0.15 mm maximum per side are not included.

OUTLINE VERSION	REFERENCES				EUROPEAN PROJECTION	ISSUE DATE
	IEC	JEDEC	EIAJ			
SOT163-1	075E04	MS-013AC				95-01-24 97-05-22

---

## Double mixer/oscillator for TV and VCR tuners

---

TDA5332T

### SOLDERING

#### Introduction

There is no soldering method that is ideal for all IC packages. Wave soldering is often preferred when through-hole and surface mounted components are mixed on one printed-circuit board. However, wave soldering is not always suitable for surface mounted ICs, or for printed-circuits with high population densities. In these situations reflow soldering is often used.

This text gives a very brief insight to a complex technology. A more in-depth account of soldering ICs can be found in our "IC Package Databook" (order code 9398 652 90011).

#### Reflow soldering

Reflow soldering techniques are suitable for all SO packages.

Reflow soldering requires solder paste (a suspension of fine solder particles, flux and binding agent) to be applied to the printed-circuit board by screen printing, stencilling or pressure-syringe dispensing before package placement.

Several techniques exist for reflowing; for example, thermal conduction by heated belt. Dwell times vary between 50 and 300 seconds depending on heating method. Typical reflow temperatures range from 215 to 250 °C.

Preheating is necessary to dry the paste and evaporate the binding agent. Preheating duration: 45 minutes at 45 °C.

#### Wave soldering

Wave soldering techniques can be used for all SO packages if the following conditions are observed:

- A double-wave (a turbulent wave with high upward pressure followed by a smooth laminar wave) soldering technique should be used.
- The longitudinal axis of the package footprint must be parallel to the solder flow.
- The package footprint must incorporate solder thieves at the downstream end.

During placement and before soldering, the package must be fixed with a droplet of adhesive. The adhesive can be applied by screen printing, pin transfer or syringe dispensing. The package can be soldered after the adhesive is cured.

Maximum permissible solder temperature is 260 °C, and maximum duration of package immersion in solder is 10 seconds, if cooled to less than 150 °C within 6 seconds. Typical dwell time is 4 seconds at 250 °C.

A mildly-activated flux will eliminate the need for removal of corrosive residues in most applications.

#### Repairing soldered joints

Fix the component by first soldering two diagonally- opposite end leads. Use only a low voltage soldering iron (less than 24 V) applied to the flat part of the lead. Contact time must be limited to 10 seconds at up to 300 °C. When using a dedicated tool, all other leads can be soldered in one operation within 2 to 5 seconds between 270 and 320 °C.

# Double mixer/oscillator for TV and VCR tuners

TDA5332T

## DEFINITIONS

<b>Data sheet status</b>	
Objective specification	This data sheet contains target or goal specifications for product development.
Preliminary specification	This data sheet contains preliminary data; supplementary data may be published later.
Product specification	This data sheet contains final product specifications.
<b>Limiting values</b>	
Limiting values given are in accordance with the Absolute Maximum Rating System (IEC 134). Stress above one or more of the limiting values may cause permanent damage to the device. These are stress ratings only and operation of the device at these or at any other conditions above those given in the Characteristics sections of the specification is not implied. Exposure to limiting values for extended periods may affect device reliability.	
<b>Application information</b>	
Where application information is given, it is advisory and does not form part of the specification.	

## LIFE SUPPORT APPLICATIONS

These products are not designed for use in life support appliances, devices, or systems where malfunction of these products can reasonably be expected to result in personal injury. Philips customers using or selling these products for use in such applications do so at their own risk and agree to fully indemnify Philips for any damages resulting from such improper use or sale.